

The Rules of Ground Golf

Manual



International Ground Golf Federation

May 24, 2019 First Edition

Apr 1, 2021 Partial revision

Apr 1, 2025 Partial revision

Contents

1. The Rules of Ground Golf	1
2. Rules Explanation and Q&A	3
Section 1: Etiquette	3
Article 1: When Your Turn Is Over	3
Article 2: During Another Player's Turn	3
Article 3: Repair Any Divots and Marks	4
Section 2: Rules Related to Gameplay	4
Article 4: Gameplay	4
Article 5: Equipment	7
Article 6: Practice Hits During Gameplay	10
Article 7: Giving or Receiving Help	10
Article 8: Play the Ball as It Lies	11
Article 9: Hitting the Ball	13
Article 10: Lost and Out-of-Bounds Balls	15
Article 11: Balls Obstructing Gameplay	16
Article 12: If Ball in Play Hits Another Player's Ball	18
Article 13: If Wind Moves a Ball at Rest	20
Article 14: If Ball Enters Hole Post on First Swing	21
Article 15: Decisions During Gameplay	22
Article 16: Standard Course	22
Example of a Scorecard	24

1. The Rules of Ground Golf

Section 1: Etiquette

Article 1

Once their turn has ended, players should move quickly out of the way as to not obstruct the following player.

Article 2

Players should not talk nor stand next to or behind either the ball or the hole post during another player's turn. Players should also wait to start playing a hole until any groups in front of them have finished playing the hole.

Article 3

Players shall repair any divots or footprints left on the course before moving on to the next hole.

Section 2: Rules Related to Gameplay

Article 4: Gameplay

Following a predetermined order of play, players tee-off from the start mat and count the number of strokes taken until their ball comes to rest within the boundaries of the metal hole post (called tomari).

Article 5: Equipment

The game shall be played using approved clubs, balls, hole-posts, and start mats.

Article 6: Practice Hits During Gameplay

Practice swings that come in contact with the ball are not allowed during gameplay. Violation of this rule will result in the addition of one penalty stroke to the player's score.

Article 7: Giving or Receiving Help

Players are not allowed to receive or ask for help during their turn, including any form of advice or physical assistance. This includes using boards for stable footing, being physically supported by other players, or getting protection from wind and rain. Violation of this rule will result in the addition of one penalty stroke to the player's score.

Article 8: Play the Ball as It Lies

If a player's ball comes to rest in a thicket or long grass, then the player may only touch such obstructions to confirm the ball's location and that it is indeed his/her ball. Players may not cut grass, bend branches, or remove obstructions. Violation of this rule will result in the addition of one penalty stroke to the player's score.

Article 9: Hitting the Ball

When swinging, players should use the head of the club to properly hit the ball. They should not push or sweep it forward. Violation of this rule will result in the addition of one penalty stroke to the player's score. However, strokes that miss the ball completely shall not be counted against the player's score.

Article 10: Lost and Out-of-Bounds Balls

If a player loses a ball or hits it out of bounds, then one penalty stroke shall be added to the player's score. The ball should be placed back on the course at a spot where play is possible, but that does not move the ball closer to the hole post. The player's next hit should be taken from the spot where the ball was placed.

Article 11: Balls Obstructing Gameplay

If necessary, a player may request that balls obstructing gameplay be temporarily removed from the course. The player whose ball is interfering with play should place a marker directly behind the ball in relation to the hole post before removing the ball.

Article 12: If Ball in Play Hits Another Player's Ball

If the ball in play hits another player's ball, then the ball in play must be played from wherever it comes to rest. The ball that was hit, however, should be returned to its original position.

Article 13: If Wind Moves a Ball at Rest

Once a player has hit his/her ball, he/she may not hit their ball again while it is in motion. However, if the ball is subsequently moved by the wind, then the player should play the ball wherever it comes to rest. If the wind moves a ball into the hole post, then it is tomari (the player holes out).

Article 14: If Ball Enters Hole Post on First Swing

If a player hits the ball into the hole post on his/her first stroke (a hole-in-one), then three strokes per hole-in-one shall be subtracted from the player's No. of Actual Strokes.

Article 15: Decisions During Gameplay

Gameplay is self-officiated. When there is a difficult call to make, the player should seek a consensus with other players.

Article 16: Standard Course

A standard course is made up of a total of 8 holes, including 2 holes for each distance of 50m, 30m, 25m, and 15m.

[Example of a Standard Course]

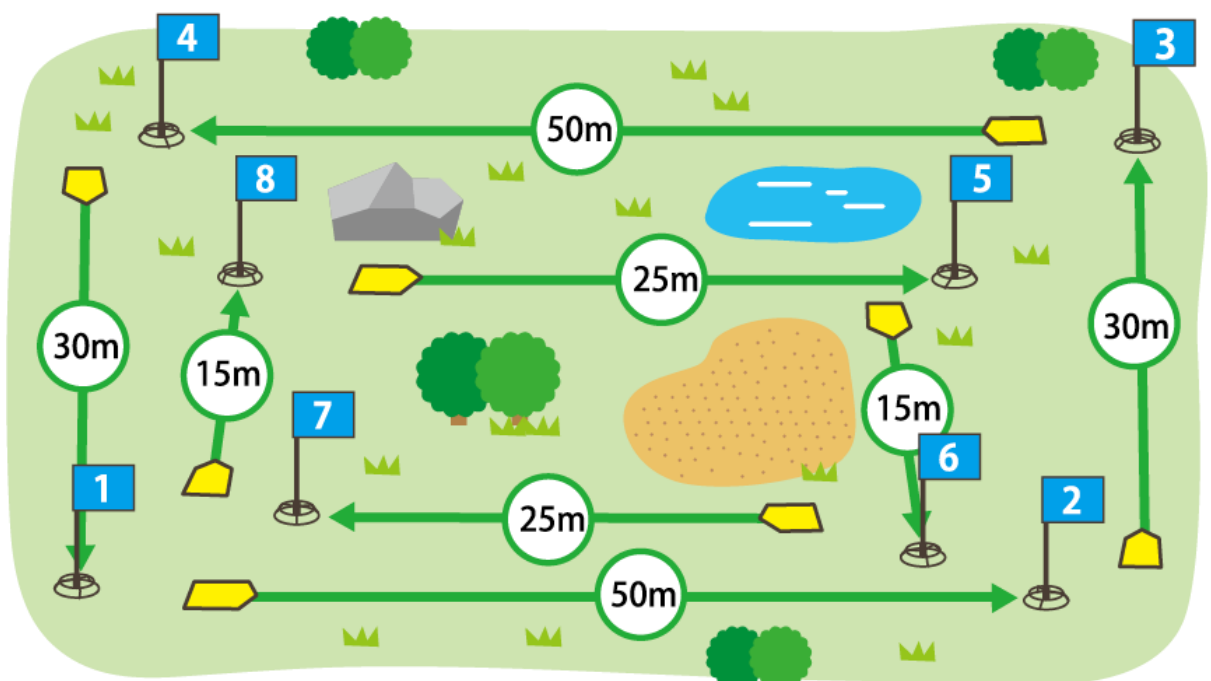

2. Rules Explanation and Q&A

In this section, we present a more detailed explanation of the rules. We have also compiled and addressed various questions submitted by ground golf enthusiasts in a Q&A format.

We hope to help provide readers with a correct understanding of the rules of Ground Golf so that they are better able to enjoy the sport with their friends and associates.

There are only 16 rules in Ground Golf. These rules are very simple and were designed to ensure that anyone could play the sport anytime and anywhere.

Additionally, a section on etiquette has been placed at the beginning of the list of rules. The emphasis placed on manners in Ground Golf is a characteristic not seen in most other sports. It would not be an exaggeration to say that this is the driving philosophy at the heart of Ground Golf.

It is important to have a correct understanding of the rules not only for day-to-day play with friends and colleagues, but also to facilitate friendly competition between players at various tournaments. It is our wish that readers will learn from the detailed explanations and Q&A sections contained herein and become exemplary Ground Golf players.

Here are a few items to keep in mind.

- Play it as it lies.
- Do not disturb other players or do things that might make them feel uncomfortable.
- Do not make decisions during gameplay that give you an unfair advantage.
- If there is a difficult call to make, consult with other players before making a decision.

We hope that this explanation of the rules and Q&A will be of use to Ground Golf enthusiasts across the countries around the world.

Section 1: Etiquette

Article 1: When Your Turn Is Over

Once their turn has ended, players should move quickly out of the way as to not obstruct the following player.

【Move to the Vicinity of Your Ball】

• You may stand in the vicinity of where your ball has come to rest, provided that you do not obstruct other players.

【Get Out of the Hole Quickly】

• Once all members of the group have finished playing a hole, the group should proceed promptly to the next hole. Please refrain from checking scorecards until you have moved to the next hole.

Article 2: During Another Player's Turn

Players should not talk nor stand next to or behind either the ball or the hole post during another player's turn. Players should also wait to start playing a hole until any groups in front of them have finished playing the hole.

【Be Quiet When Others Are Preparing to Swing】

• Talking and interacting with other players is part of the fun of Ground Golf. However, players should not talk in a loud voice, laugh, or move around when another player is getting ready to take his/her shot.

【Focus on Safety】

• There is a strong possibility of being hit with another player's club if one stands too close to the other player while he/she is taking his/her swing. Players are encouraged to be careful during gameplay.

【Wait for Other Groups to Finish Before Starting a Hole】

• Players should wait for any groups in front of them to finish using a hole before placing a ball on the start mat.

Article 3: Repair Any Divots and Marks

Players shall repair any divots or footprints left on the course before moving on to the next hole.

【Fix Marks Before Moving On】

• Depending on the weather and facilities being used, there are occasions where the movement of the players may leave marks and footprints on the ground.

• Show consideration for other players by repairing (as far as practicable) any divots or footprints before moving on.

• If the grounds are muddy, then players should do their best to avoid areas where their balls may get stuck.

Q1: If the player before you left a divot right in front of the start mat and moved on without fixing it, would it be okay to go ahead and fix it?

A: The player may fix the divot if he/she deems it necessary. However, he/she should be sure to tee-up quickly regardless of his/her decision.



Section 2: Rules Related to Gameplay

Article 4: Gameplay

Following a predetermined order of play, players tee-off from the start mat and count the number of strokes taken until their ball comes to rest within the boundaries of the metal hole post (called tomari).

【Decide the Order of Play Before Beginning Gameplay】

• Players should agree on the order of play before beginning gameplay.

- For tournaments and training sessions, players will be notified of the order of play as determined by the host or organizer. At all other times, players decide among themselves.
- Players should follow the same order of play for each turn on a hole, from the first stroke until someone holes-out (gets a tomari).

【Hitting Consecutively】

- Players are not allowed to take two shots in a row until someone holes-out. In other words, taking two turns in a row is not permitted.

【How to Hole-Out (Tomari)】

- To finish a hole (get a tomari), at least half of the player's ball must come to rest within the boundary of the bottom ring of the hole post.

When making such a decision, players should look at the position of the ball in relation to the bottom ring of the hole post from directly above where it came to rest.

It is also considered "tomari" if the ball lands on the upper ring of the hole post.

Q2: What different types of orders of play are there?

A: There is a "Fixed Order of Play," where players follow the same pre-determined hitting order throughout the game, as well as a "Rotating Order of Play," where players move up the hitting order one spot for each hole played.

Fixed Order of Play

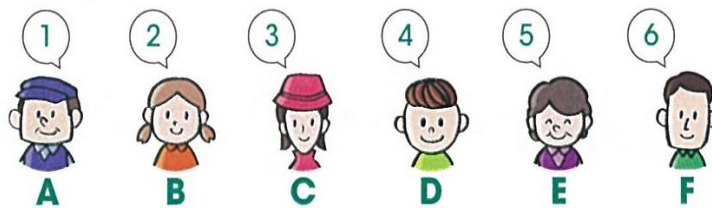

- Ex:
- Order of Play for Hole 1: A→B→C→D→E→F
 - Order of Play for Hole 2: A→B→C→D→E→F

Rotating Order of Play

Everyone moves up one spot on the hitting order each round

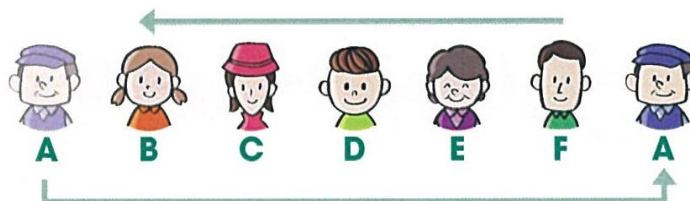

Whoever went first on the previous hole goes last one the following hole.

- Ex:
- Order of Play for Hole 1: A→B→C→D→E→F
 - Order of Play for Hole 2: B→C→D→E→F→A
 - Order of Play for Hole 3: C→D→E→F→A→B

Players continue to move up a spot on the hitting order for each following hole played.

Q3: What should I do if I accidentally mess up the order of play?

A: If you accidentally play out of turn, be sure to go back to the correct order of play from your next turn. No penalty stroke will be added to the player's score.



Q4: If the ball lands right next to the hole post, is it okay to just go ahead and hit it in?

A: If your ball is very close to the hole (the width of a club head or less), you may take another shot immediately. This avoids troubles regarding to place a marker.

It is proper etiquette for players to politely inform other players that they are going to go ahead and hit the ball in. The Japanese for this is "O-saki ni shitsurei!"



Q5: What should I do if I accidentally hit another player's ball?

A: The player whose ball was accidentally hit should return it to its original position. The player who accidentally hit the incorrect ball should then re-do the shot with his/her ball.

No penalty stroke will be added to the player's score.

The same applies if you accidentally take your shot from another player's marked position.

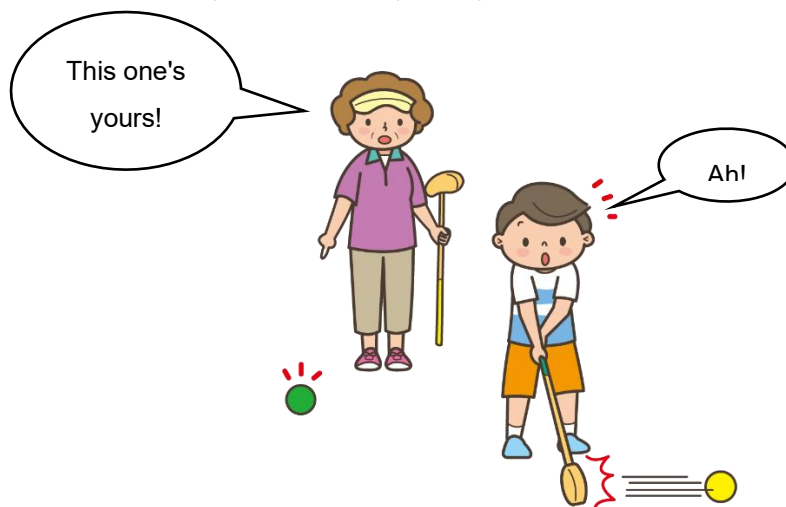

Q6: Does a player hole-out (get a tomari) if the ball comes to rest right on top of the bottom ring of the hole post?

A: Yes, that is tomari (the player holes-out).

When making such a decision, players should look at the position of the ball in relation to the bottom ring of the hole post from directly above where it came to rest.

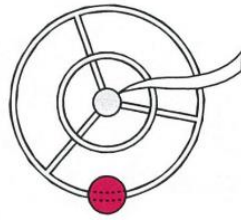

If the ball comes to rest right on top of the bottom ring of the hole post and at least half of the ball is within the boundary of the hole post, then it is tomari!

Article 5: Equipment

The game shall be played using approved clubs, balls, hole posts, and start mats.

【Equipment to use】

- The club, ball, hole post, and start mat used must be equipment manufactured in accordance with the International Ground Golf Federation equipment standard rules.

【Equipment Modifications】

- Players are permitted to apply grip tape or shorten the club as long as it remains within the allowed specifications. However, other modifications are strictly prohibited.
- If a player chooses to affix his/her initials or any other mark to his/her club, then the player should only add enough to be able to identify it as his/hers and must not change how it functions in any way.
- It is important to understand that this is for safety reasons.

Club

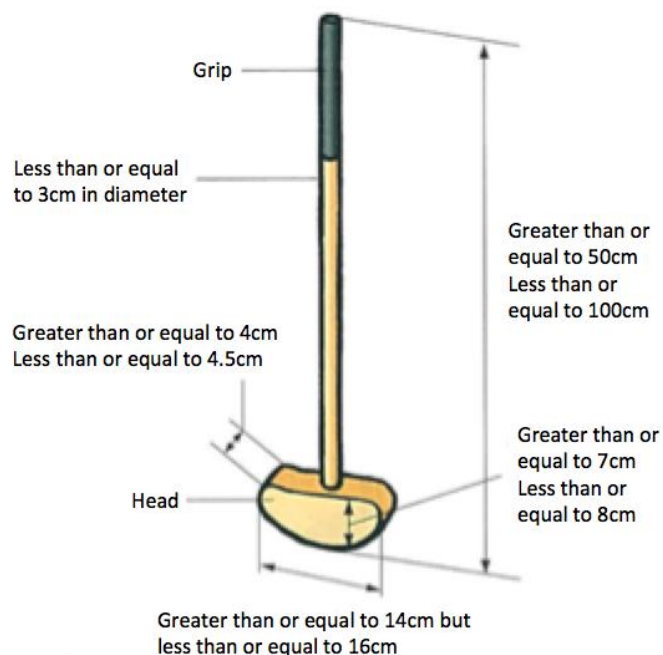

Ball

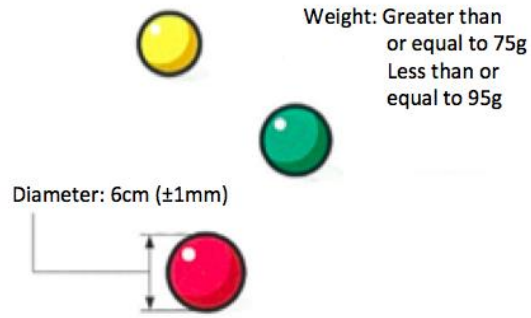

Hole Post

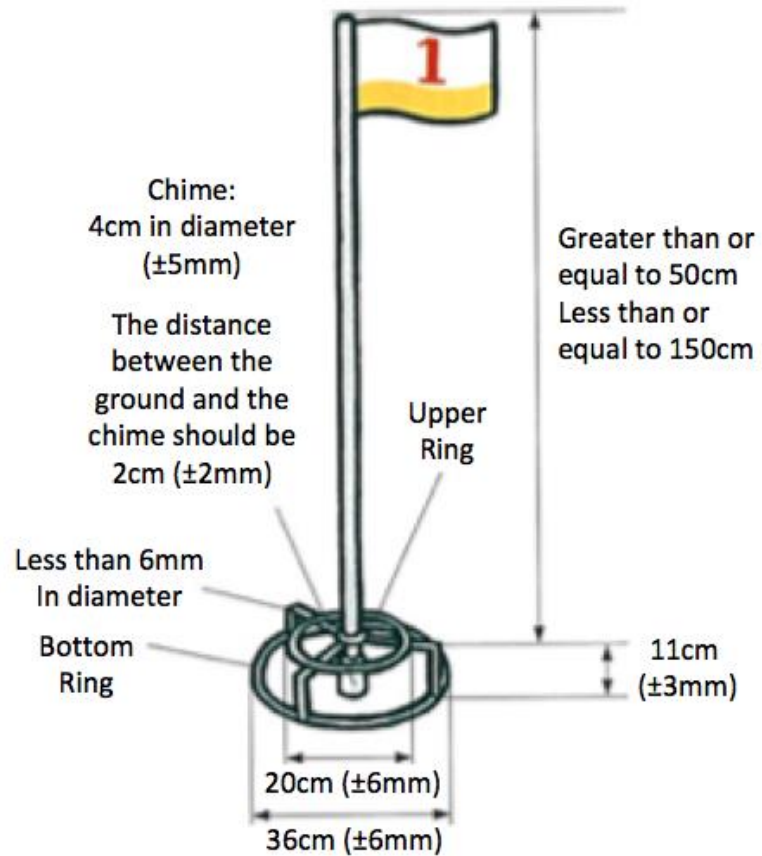

Start Mat

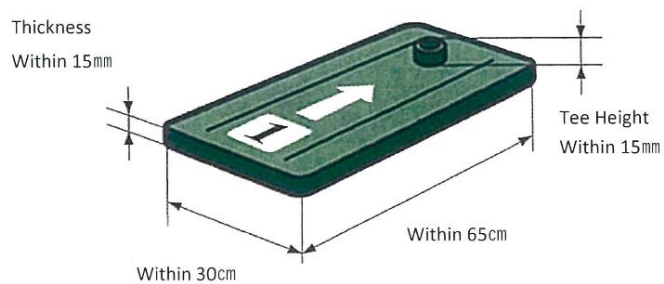

Q7: How can I confirm the certified equipment ?

A: "Japan Ground Golf Association Certified Product (公益社団法人日本グラウンド・ゴルフ協会認定品)" will be written on all approved clubs, hole posts, and start mats. The letters "JGGA (認)" will be written on all approved Ground Golf balls.

A certification sticker will also be affixed to all approved equipment. However, equipment is still considered to be approved equipment even if this sticker is comes off and is lost.

Certification Sticker Placement

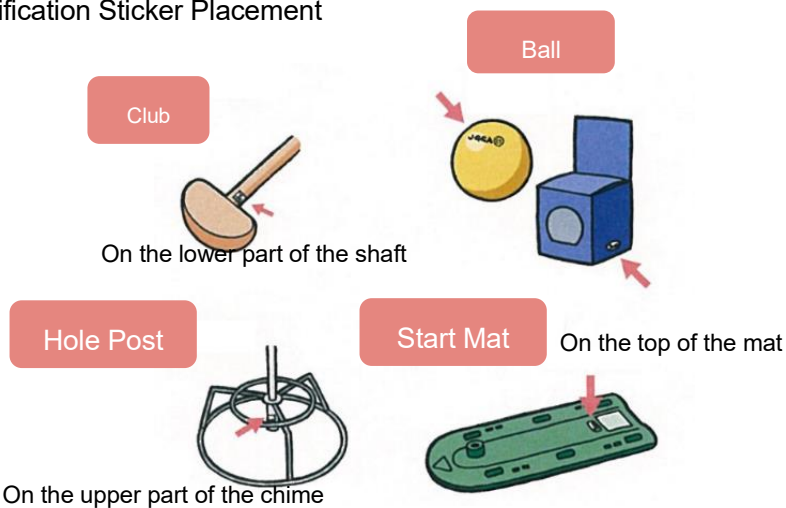

Certification Sticker



Q8: Is it okay to attach a thin tape or film to protect the head of the club?

A: Players are not allowed to affix tape or film to the head of the club as the functioning of the club may be affected by the thickness or materials used.

If there is an explanatory seal on the head of the club at the time of purchase, then you should remove it before use.

Q9: Is it okay to adjust the length of the club and shorten it to fit my height?

A: You may shorten the club as long as it remains within the length requirements (at least 50cm but less than or equal to 100cm).



Q10: Is it okay to switch out my ball or club during gameplay?

A: You are not allowed to switch out equipment during gameplay.

However, you may change equipment after finishing a complete round (8 holes).

If your club breaks or your ball cracks during gameplay, then you are allowed to switch out your equipment at that time. Be sure to check with the other players in your group or the host organization first.

Article 6: Practice Hits During Gameplay

Practice swings that come in contact with the ball are not allowed during gameplay. Violation of this rule will result in the addition of one penalty stroke to the player's score.

【Practice Hits During Gameplay】

- Practice hits are against the rules and will result in the addition of one penalty stroke to the player's score. Practicing your swing is allowed, but practice shots that involve actually hitting the ball are not.

If you decide to practice your swing, please be sure to pay attention to the safety of those around you. You must also stop and wait quietly while other players are taking their shot.

【Practicing During a Tournament】

- Check with the host organization if you wish to practice on the course prior to a tournament.

If the hosting organization is silent on the matter, it is proper etiquette not to practice on the course before the event.

Article 7: Giving or Receiving Help

Players are not allowed to receive or ask for help during their turn, including any form of advice or physical assistance. This includes using boards for stable footing, being physically supported by other players, or getting protection from wind and rain. Violation of this rule will result in the addition of one penalty stroke to the player's score.

【Players Are Not Allowed to Receive Assistance】

- Ground Golf is a sport that emphasizes responsibility for one's self. Having someone hold an umbrella for you in the rain, having someone hold back branches that interferes with your swing, or having someone support you from behind where the ground is unsteady, constitute a rule violation punishable with one additional penalty stroke.

- If an individual with disabilities asks for assistance with certain tasks, such as marking his/her ball, it is permitted to help him/her.

- Chatting with other players is one of the great pleasures of Ground Golf—but be careful not to accidentally give out advice!

- Asking questions about the rules is not a violation.

- Players should decide on such issues before beginning gameplay.

Q11: If the ground is sloped, making it difficult to hit, would it be okay to place something down to help me aim?

A: It is okay to aim for rocks, branches, sandy areas, etc., that are already on the ground; however, you are not allowed to place a new item down to assist in aiming.

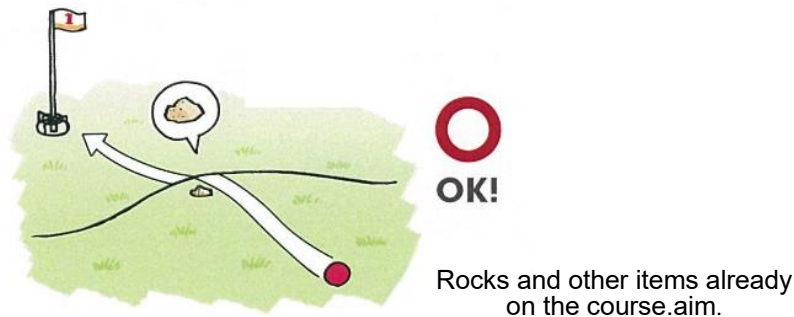

Q12: The hole post is bending over in the wind, so another player offers to hold it in position while play continues. Does this constitute assistance?

A: No, a player holding the hole post in position does not constitute assistance.

The hole post should be secured with weights or U-shaped stakes to prevent it moving or falling over during play.

A player may not hold the hole post and hit the ball at the same time.

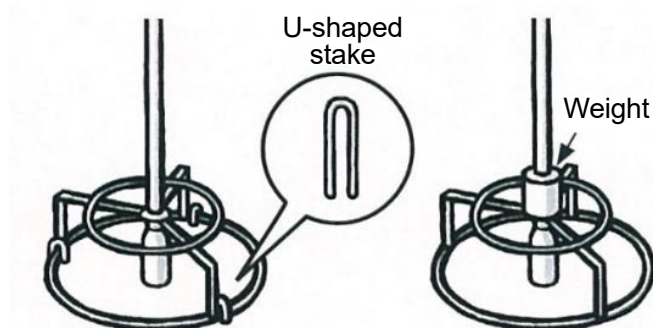

Article 8: Play the Ball as It Lies

If a player's ball comes to rest in a thicket or long grass, then the player may only touch such obstructions to confirm the ball's location and that it is indeed his/her ball. Players may not cut grass, bend branches, or remove obstructions. Violation of this rule will result in the addition of one penalty stroke to the player's score.

【Play the Ball as It Lies】

- There are times when a ball enters an area with long grass or a thicket and the player is unable to hit it. Players may not try to gain an advantage by, for example, stamping down or pulling out grass, or breaking off tree branches, in the vicinity of the ball. Similarly, players must not try to smooth out natural undulations. Players are to play the ball as it lies.

Such violations attract a penalty of one additional stroke.

【Players May Not Remove Obstructions】

- Regardless of how difficult it is to take a swing, players are not allowed to adjust the environment around the ball to their advantage. As such, players may not remove obstructions such as rocks, branches, sand, markers, etc., that lie between the ball and the hole post.
 - Once play has begun, players are not allowed to remove any objects that may be seen as obstructions, including fallen branches, rocks, bugs, and animal droppings.
- However, these may be removed before the first round of play.

【Obstacles and Obstructions on a Course 】

- Players are not permitted to move other hole posts and objects set within the course. If the wind, for example, moves them after play commences, they should be returned to their original position.

Q13: Is it okay to remove rocks, branches, leaves, and other such items?

A: No, you must play the ball as it lies, regardless of the surroundings.

If you remove any obstructions, then one penalty stroke will be added to your score for that hole.

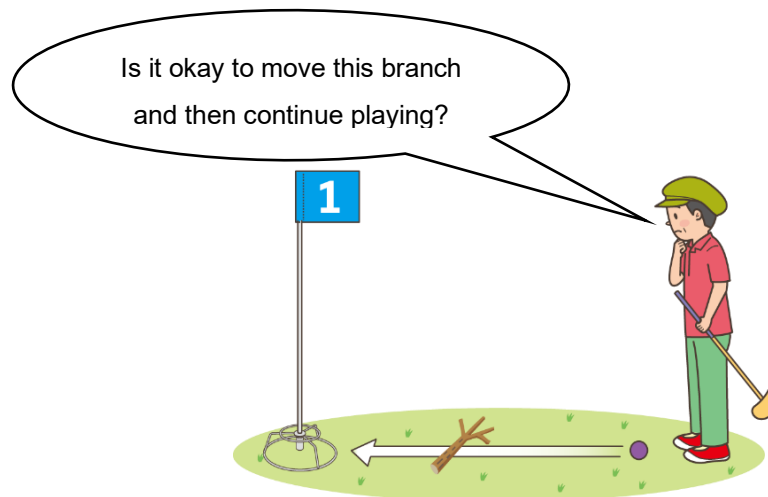

Q14: What happens if a ball is hit and it comes to rest within the boundaries of the hole post of a different hole?

A: If you can hit the ball from where it stopped, then you should play from where it came to rest. However, if you are unable to hit the ball, then, without moving it closer to your hole post, you may move it within the length of a club and resume gameplay from there.

However, one penalty stroke will be added to your score.

All other objects on the course that are considered to be immovable obstructions are to be treated in the same manner.

Q15: If the hole post moves after being struck by a ball or a club, when should it be moved back to its original position?

A: If a player notices that the hole posts and objects have moved before the group starts a new hole, they should be returned to their original position immediately.

- If the hole post is knocked out of position by a ball or club during play, it should be returned to its original position at that time.
- If nobody notices that the hole post has moved until after the group has started the hole, then it must remain in that position until all players have finished the hole.

Article 9: Hitting the Ball

When swinging, players should use the head of the club to properly hit the ball. They should not push or sweep it forward. Violation of this rule will result in the addition of one penalty stroke to the player's score. However, strokes that miss the ball completely shall not be counted against the player's score.

【Hitting the Ball】

- Any swing that drags the ball along without properly hitting it, including double hitting, scooping, pushing, or sweeping, is not allowed. Such violations attract a penalty of one additional stroke.

【Swings that Don't Come into Contact with the Ball】

- An empty swing is where the club does not come into contact with the ball when a player takes a swing.

- Empty swings do not count against a player's score.

Q16: What part of the club head should I use to hit the ball?

A: You should hit the ball with the "face" of the club head. However, if the ball is very close to the hole post (the width of the club head or less) or where space is limited and it is difficult to hit the ball with the face of the club head, you may use any part of the club head to hit the ball.

Q16: What part of the club head should I use to hit the ball?

A: You should hit the ball with the "face" of the club head. However, if you are right next to the hole post, or if you are in an especially narrow area, then it is okay to use any part of the club head to hit the ball. However, if the ball is very close to the hole post (the width of the club head or less) or where space is limited and it is difficult to hit the ball with the face of the club head, you may use any part of the club head to hit the ball.

Some club heads can be used on both sides.

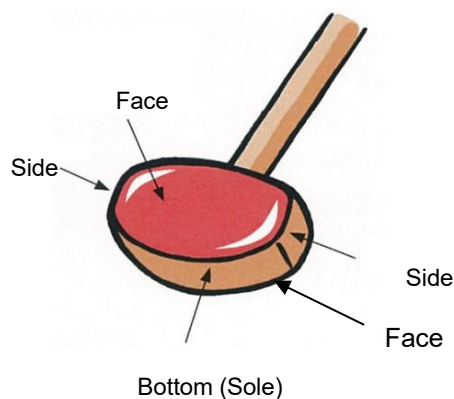

Q17: Is it okay to flip the club over and hit the ball with the grip of the club?

A: You may not hit the ball with any part of the club other than the head, including the grip end. You may not hold the head of the club to hit the ball.

Such violations attract a penalty of one additional stroke.



addition of one penalty stroke



Q18: Is it okay to straddle the intended line of play between the ball and the hole post and hit the ball in that position?

A: It is not allowed to straddle the intended line of play between the ball and hole post, or any extension of the intended line of play.

Such violations attract a penalty of one additional stroke.

Such swings are viewed as violating the rule of hitting the ball correctly with the head of the club, similar to pushing or sweeping the ball.



It might be easier to hit the ball in like this!

Q19: Is okay to redo my turn if my club accidentally comes into contact with the ball when getting into my address position (getting ready to take a swing) and the ball moves?

A: You may not redo your shot. If you have addressed the ball and your club then hits the ball, causing it to move, this counts as a shot. On your next turn you must play the ball from where it has come to rest. However, if the ball comes into contact with the club when you are preparing to swing but does not fall off the tee, then it does not count as a taking a hit.

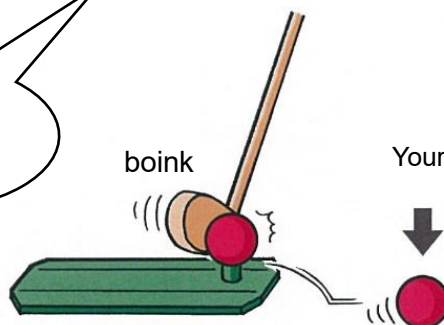
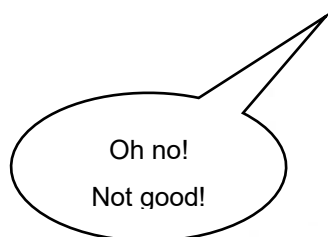

Your next shot should be taken from this position.

Q20: What should you do if your club misses the ball on your first swing, but the ball still falls off the tee?

A: If you swing and miss the ball, yet the ball moves from the force of the swing, or if the ball falls from the force of the club hitting the start mat, then it is not counted as a hit. You should return the ball to the tee and redo your turn.

No penalty stroke is added to the player's score.

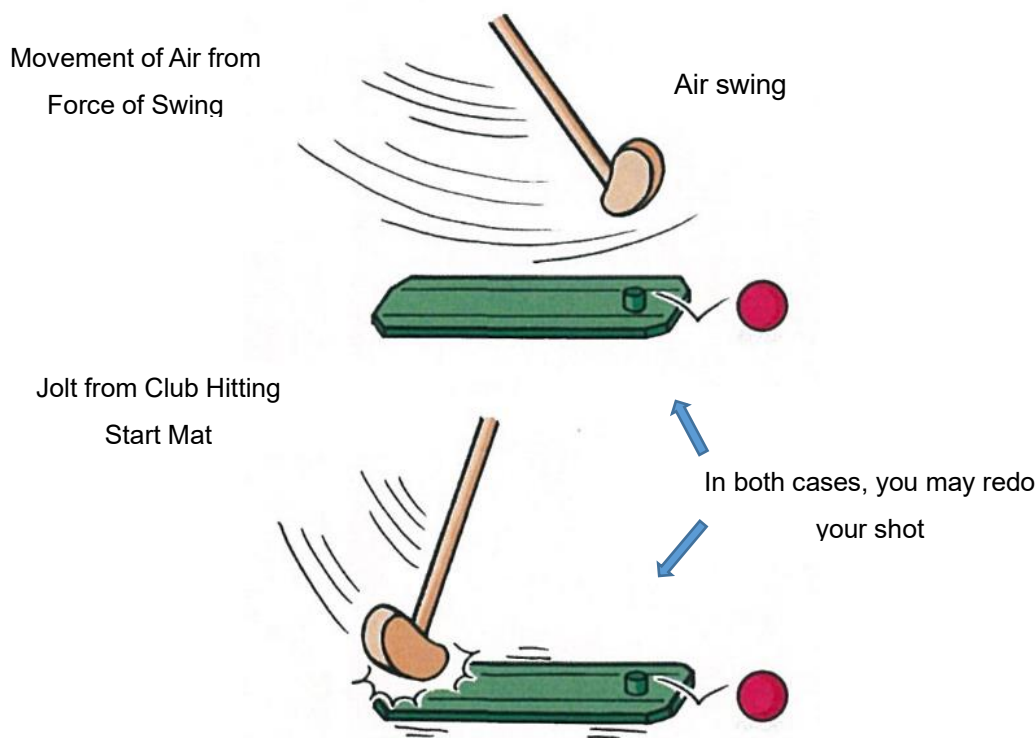

Article 10: Lost and Out-of-Bounds Balls

If a player loses a ball or hits it out of bounds, then one penalty stroke shall be added to the player's score. The ball should be placed back on the course at a spot where play is possible, but that does not move the ball closer to the hole post. The player's next hit should be taken from the spot where the ball was placed.

【Lost Balls】

- If a ball can't be found after entering a thicket or thickly wooded area, then, without placing it closer to the hole post, the player should place the new ball on the course where the other one went out of sight.

One penalty stroke should be added to the player's score.

【Out of Bounds or Unplayable Ball】

- If a ball goes out of bounds and lands in a pond, river, gutter or other location considered unplayable (typically due to obstruction), the restart position shall be the point on the fairway closest to where the ball landed.

- You may place the ball up to one club length away from the restart position so as to make the ball playable, provided that it is no closer to the hole. The player will incur a penalty of one additional stroke. One penalty stroke should be added to the player's score.

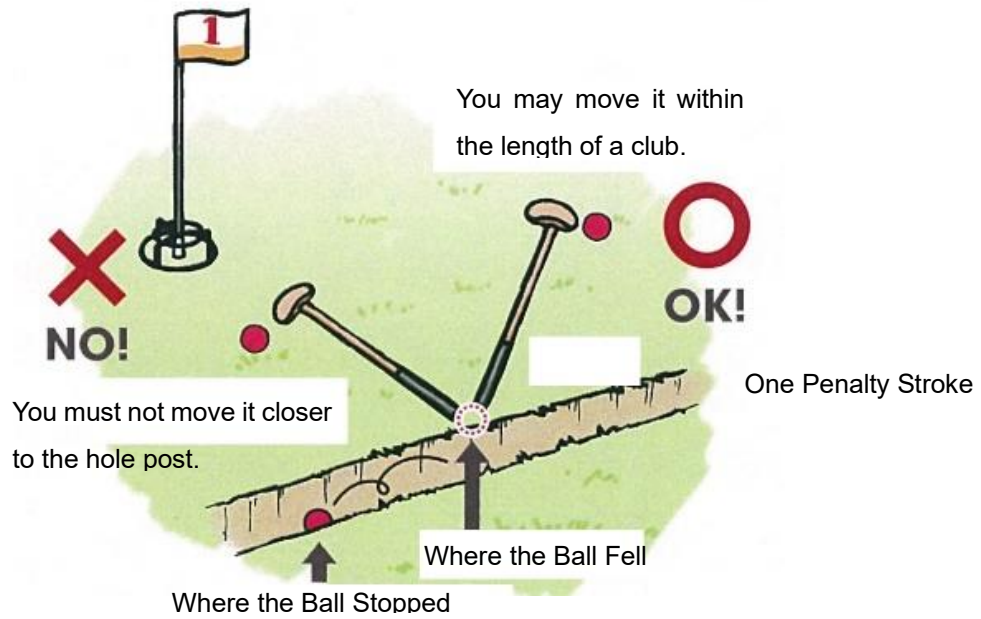

Q21: After moving my ball and adding a penalty stroke to my score, may I then take a swing during the same turn?

A: No, you are not allowed to hit the ball on the same turn you moved it. You must wait for your next turn.

Q22: What happens if a ball goes out of bounds, but then comes to rest back within the bounds of the course?

A: If the ball stops within the bounds of the course, then you should play it from where it came to rest.

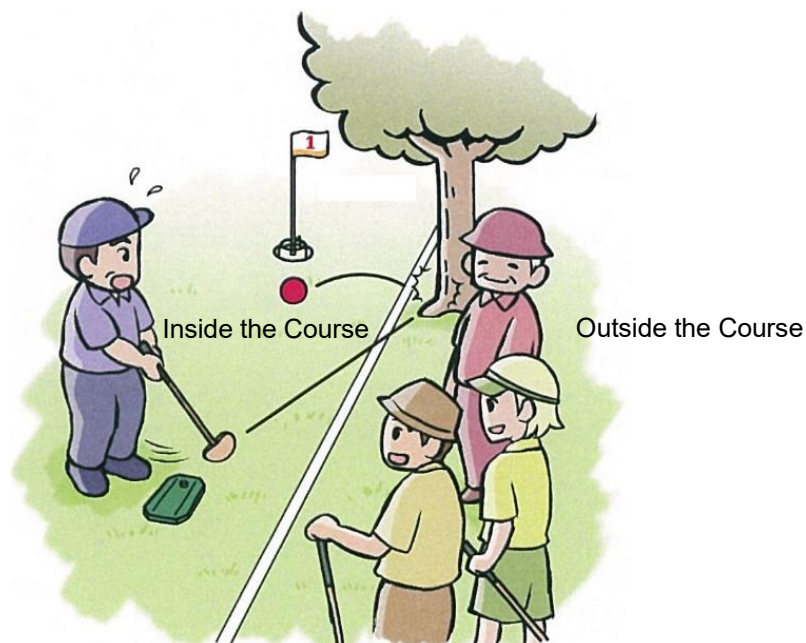

Article 11: Balls Obstructing Gameplay

If necessary, a player may request that balls obstructing gameplay be temporarily removed from the course. The player whose ball is interfering with play should place a marker directly behind the ball in relation to the hole post before removing the ball.

【Removing the Ball】

- When you are preparing to take your swing, if it looks like you might hit another player's ball with your ball if you play things as they lie, then you may request that the other player temporarily remove his/her ball from the course.

If it looks like your ball might get in the way of another player's shot, then it is good etiquette to mark your ball and remove it from play before he/she asks you to do so.

- If your ball is close to the hole post or in another player's line of aim, you should remove it after placing a marker.

【Removing Your Ball from the Field】

- Remove your ball only after placing your marker behind it. Remove your marker only after placing your ball back in its original position.

【Marker】

- The marker used should be something that does not get in the way of gameplay. You should not use anything too big or too thick.

- The marker should be about 20mm in diameter and about 2mm thick (ribbons and other items of approximately 30mm may be attached to the marker).

- Using a coin as a marker is not recommended.

Q23: How should balls at rest that look like they might get in the way of another player's shot be removed?

A: The relevant player should place a marker behind the ball (relative to the hole post) then remove their ball.

At their turn, the player replaces the ball in front of the marker and removes the marker before playing their shot.

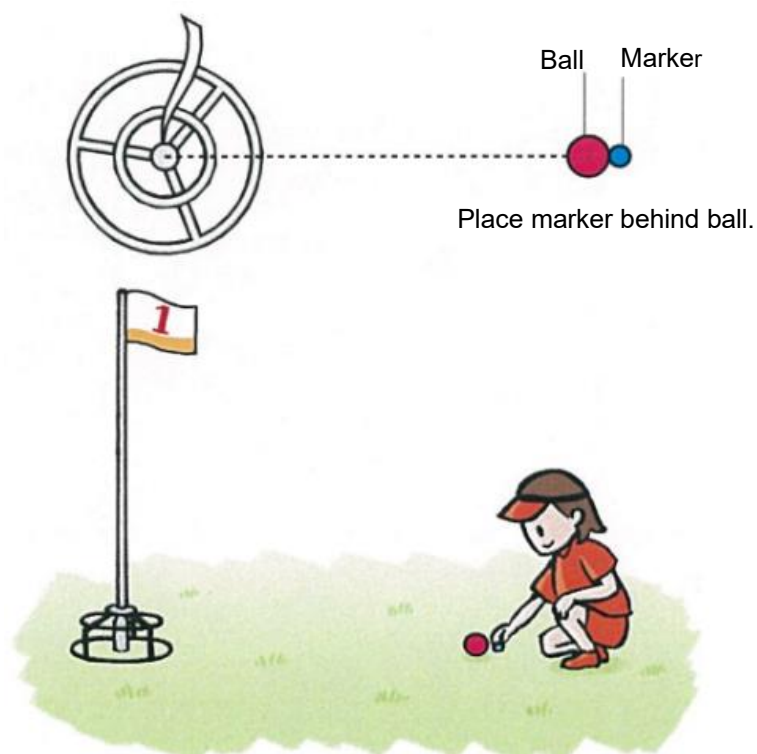

Q24: Can I ask another player to leave their ball on the ground prior to taking my shot?

A: You may not.

You are not allowed to use another player's ball as a way to direct your ball into the hole.

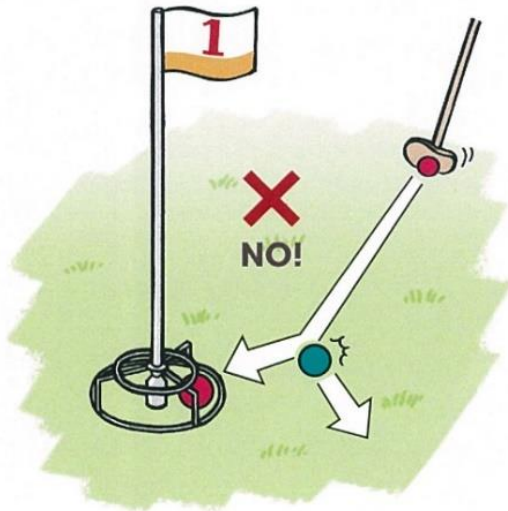

You may not request that another player leave his/her ball on the field.

Q25: When preparing to swing, if I notice that another player's marker is lying along my line of aim, is it okay to ask the other player to move their marker to the side?

A: No, you may not ask another player to move his/her marker out of the way. Other players' markers are treated in the same way as pebbles, branches, sand and other items naturally found on the ground.

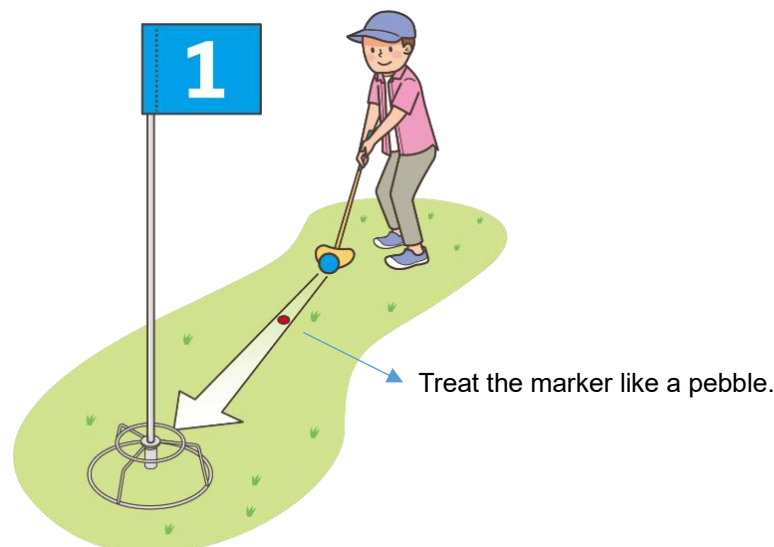

Article 12: If Ball in Play Hits Another Player's Ball

If the ball in play hits another player's ball, then the ball in play must be played from wherever it comes to rest. The ball that was hit, however, should be returned to its original position.

【If Your Ball Hits A Ball at Rest】

• Unforeseeable events may occur during gameplay. Even if a player is careful, his/her ball may end up accidentally hitting another player's ball. If that happens, the other player returns their ball to its former position before taking their shot. The ball that hit the other ball should be played from wherever it comes to rest.

【Be Careful of Spectators and Other Players' Balls】

• In addition to being careful of spectators and other players' balls, players should mark and remove balls that might affect gameplay.

Q26: What should I do if my ball hits another player's ball?

A: If your ball strikes another ball, your next shot is taken from wherever your ball comes to rest. The other player returns their ball to its original position before taking their shot.

If two moving balls come into contact, each player takes their next shot from where their ball comes to rest.

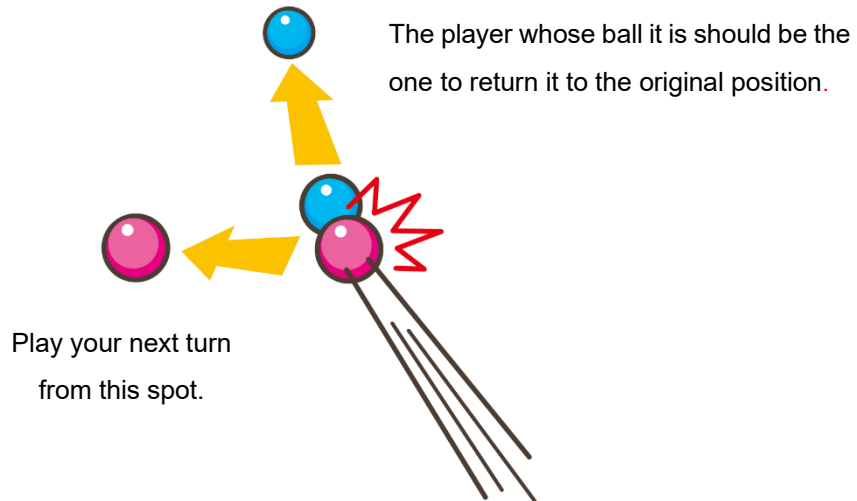

Q27: What happens if the ball I hit comes into contact with another player's ball and my ball lands within the boundaries of the hole post? Similarly, what happens if the ball that my ball hit comes to rest within the boundaries of the hole post?

A: If your ball comes to rest within the boundaries of the hole post, then you hole-out (it's tomari). However, if the other player's ball lands within the hole post, the other player does not hole-out (it's not tomari). The player whose ball was hit should return it to its original resting position.

As a precaution, any ball in a position that could potentially influence the trajectory of another ball should be removed by its owner and replaced with a marker.

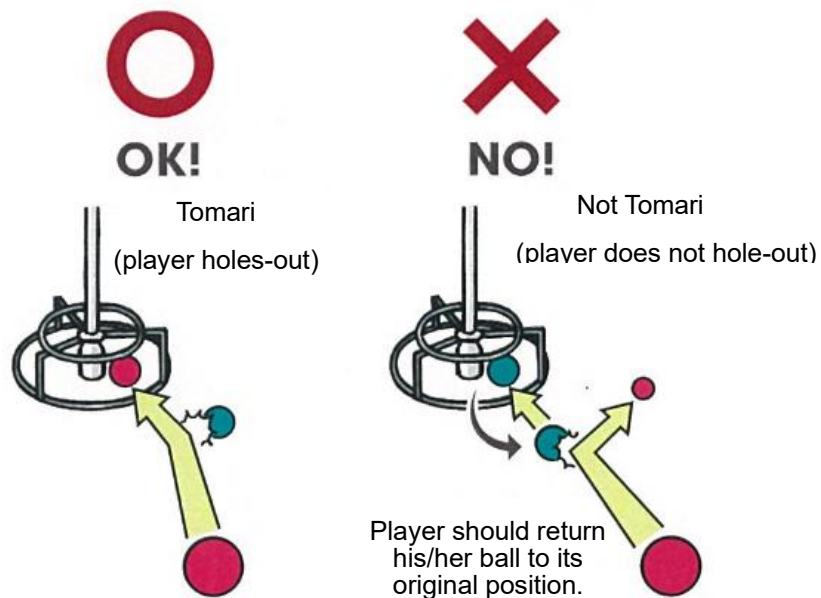

Q28: What should I do if my ball accidentally hits another player?

A: If your ball hits a spectator or another player, then it is treated as a rock, branch, or other obstruction on the course and you should play the ball from wherever it comes to rest



Article 13: If Wind Moves a Ball at Rest

Once a player has hit his/her ball, he/she may not hit their ball again while it is in motion. However, if the ball is subsequently moved by the wind, then the player should play the ball wherever it comes to rest. If the wind moves a ball into the hole post, then it is tomari (the player holes out).

【Ball at Rest Moved by Forces of Nature】

- Efforts were made when designing the Ground Golf ball to help prevent it from being moved by strong winds. Nevertheless, there is a part of nature that cannot be worked into calculations, and, as such, there is no guarantee that a ball will not be moved by the wind. There are also occasions where players may have to play on an especially windy day.

If the wind moves your ball, you must play the ball from wherever it comes to rest.

【Ball at Rest Moved by Outside Agency】

- If a ball at rest is moved by outside forces other than nature, as in the following examples, then the player should move his/her ball to its original position before resuming play.

- If birds, dogs, or other animals move the ball
- If spectators move the ball
- If you accidentally hit another player's ball thinking it was yours
- If another player's ball hits your ball

Q29: What should I do if my ball is moved by the wind?

A: If your ball is moved by the wind, then you should play the ball from the position where it comes to rest.

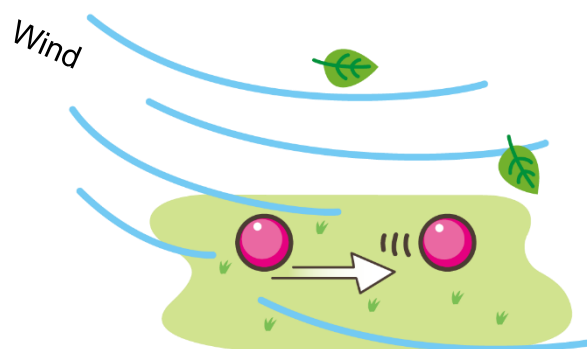

Play from where the ball stops.

Article 14: If Ball Enters Hole Post on First Swing

If a player hits the ball into the hole post on his/her first stroke (a hole-in-one), then three strokes per hole-in-one shall be subtracted from the player's No. of Actual Strokes.

【Subtract Three】

• It is called a "hole-in-one" when a player hits his/her ball into the hole post (gets a tomari) on his/her first stroke. Three strokes will be subtracted from the player's No. of Actual Strokes for each hole-in-one.

• One of the attractions of Ground Golf is the fact that "Anyone can win." The three stroke bonus for a hole-in-one is a wildcard rule that can help a player come from behind and win!

【How to Mark the Scorecard for a Hole-in-One】

• In order to avoid any confusion later on, players should mark the scorecard with a ① when a player gets a hole-in-one. The "Total" column on the scorecard should show the final number of strokes after subtracting three strokes per hole-in-one.

【Scorecard】

• The standard scorecard used by the International Ground Golf Federation is shown below. The tournament host will notify players on how scorecards are to be filled out. In all other cases, the players may discuss and decide amongst themselves.

Q30: What should the scorecard look like?

A: There are no specific regulations regarding the setup of the scorecard; however, the International Ground Golf Federation uses the following example as a standard scorecard.

Scorecard

International Ground Golf Federation

Tournament Name ()	Course Name ()	Starting Hole No. ()	Year	Month	Day ()
---------------------	-----------------	-----------------------	------	-------	---------

No.	Name	Hole No.								No. of Actual Strokes	No. of Hole-in-Ones	Total	Confirmation Signature

Notes

(1) How to Mark the Scorecard

The number of strokes for the round should be marked using Arabic numerals

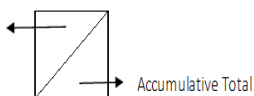

(2) If a player gets a hole-in-one, then he/she should fill in the "Strokes" column with a ①. He/she should also then add one to the running total and write that in the "Accumulative Total" column. The total number of strokes after subtracting three strokes for each hole-in-one should be written in the "Total" column for the player's final overall score.

Article 15: Decisions During Gameplay

Gameplay is self-officiated. When there is a difficult call to make, the player should seek a consensus with other players.

【Ground Golf is Self-Officiated by the Players】

- Ground Golf is intended as a social form of golf where gameplay is refereed by the players themselves and an independent referee is not required.

Drawing on that mentality, this was specified in Article 15 of the rules in April 1997.

【Decisions Are Made by the Players Themselves】

- There are no third party referees in Ground Golf. Rather, this role is filled by the players themselves. Ground Golf is a sport that respects the autonomy of the players to make fair decisions and cooperate with the other players. We ask that players enjoy the game with this philosophy in mind.

- If you are not sure how to adjudicate a particular shot, discuss it with the other players.

【Make Fair Decisions】

When making calls during gameplay, players should keep the following items in mind:

- You should have a solid understanding of the rules of the game.
- Do not make decisions that give yourself an unfair advantage.

Article 16: Standard Course

A standard course is made up of a total of 8 holes, including 2 holes for each distance of 50m, 30m, 25m, and 15m.

【Official Tournaments and Accredited Courses】

- Courses should be set up so that no two holes of the same distance are played consecutively (this applies to holes 1 and 8 as well).

【Other Courses】

- One of the appealing aspects of Ground Golf is that you can set up the course however you like and can play anywhere.

- For example, even if there are hills or obstructions, you can enjoy a game of Ground Golf on a sports field, on the bank of a river, at a park, in your yard, etc. It's good to choose the setup and number of holes that best matches the location being used.

Players should design a course that is appropriate for the players and location.

【Setting Up the Course】

- Two of the hole post's three legs should sit so that the open space between them is facing the start mat.

- The hole post should be set up on a flat area and the bottom ring should not be covered by any sand or grass.

- The hole post should be secured with weights or U-shaped stakes to prevent it moving or falling over during play.

- The distance for each hole should be measured from the middle of the tee on the start mat to the middle of the chime on the hole post.

- For your safety and enjoyment, there should be a minimum distance of 10 meters between start mat and hole post, and between hole posts. For 50 meter holes this distance can be extended further.

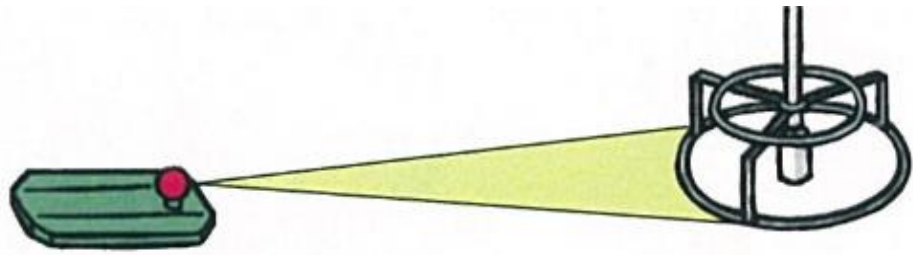

Remove any sand



Move the hole post to a spot without long grass or remove the grass.



Translated by Julianna KELEHER
Takashi IINO

Scorecard

International Ground Golf Federation

Tournament Name ()	Course Name ()	Starting Hole No. ()
		Year Month Day ()

No.	Name	Hole No.								No. of Actual Strokes	No. of Hole-In-Ones	Total	Confirmation Signature

Notes

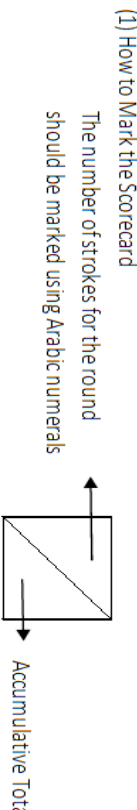

(2) If a player gets a hole-in-one, then he/she should fill in the "Strokes" column with a ①. He/she should also then add one to the running total and write that in the "Accumulative Total" column. The total number of strokes after subtracting three strokes for each hole-in-one should be written in the "Total" column for the player's final overall score.